

Two-Way Linear Actuator Connectors

for Two-Axis System, Stainless Steel

SPECIFICATION

Types

- Type **A**: Without seals
- Type **B**: With seals

Identification no.

- No. **4**: With 2 stainless steel cap nuts DIN 917

Stainless steel AISI CF-8

Matte shot-blasted

Sleeve bearing

Plastic (PTFE)

Carriage bolt DIN 603

Stainless steel

Cap nuts DIN 917 / Washers

Stainless steel

Seals

- Sealing disks
Plastic (Polyacetal POM)

- Spacer ring
Silicon, 40 ... 60 Shore A



INFORMATION

Two-way linear actuator connectors GN 132.25 are based on two-way connector clamps. The additionally provided mounting holes are used to connect to the drive key of a linear actuator. Bores with the designation **G** are equipped with sleeve bearings.

With the screw locations **z**, the play of the guide bores d_1 / d_2 can be adjusted or the linear actuator connectors can be clamped after adjustment. Type B is equipped with seals at the screw locations.

For quick clamping without tools, the cap nuts can be replaced by the adjustable hand levers GN 911.3 (see page 1875) listed in the table as accessories.

ACCESSORY

- Adjustable Hand Levers GN 911.3 (see page 1875)

TECHNICAL INFORMATION

- Plastic Characteristics (see page A2)
- Stainless Steel Characteristics (see page A26)

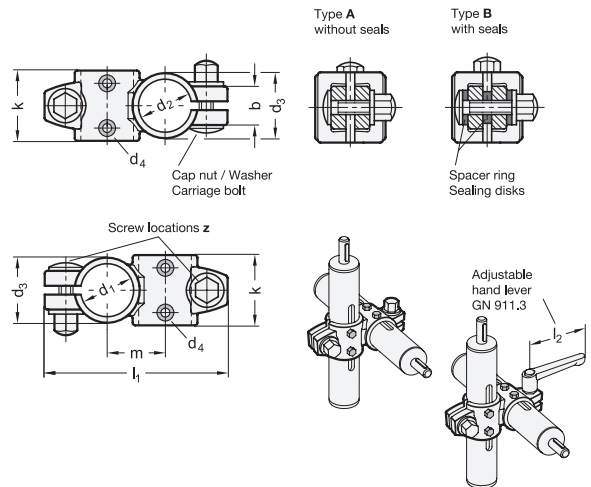

GN 132.25-A

STAINLESS STEEL

Description	d1 - d2 with sleeve bearing	b	d3	d4 Mounting screws on the drive key	k Clamping length	l1	m	z Screw locations	Accessory Recom. hand lever GN 911.3 for z l2	⚖
GN 132.25-G30-G30-A-4	G30 - G30	22	37	M 4	40	104	33	M 8	63 78	296
GN 132.25-G50-G50-A-4	G50 - G50	30	60	M 6	65	150	53	M 10	78 92	970

GN 132.25-B

STAINLESS STEEL

Description	d1 - d2 with sleeve bearing	b	d3	d4 Mounting screws on the drive key	k Clamping length	l1	m	z Screw locations	Accessory Recom. hand lever GN 911.3 for z l2	⚖
GN 132.25-G30-G30-B-4	G30 - G30	22	37	M 4	40	104	33	M 8	63 78	296
GN 132.25-G50-G50-B-4	G50 - G50	30	60	M 6	65	150	53	M 10	78 92	970